

Roller Blind Systems





Electrically Operated Roller Blind System

Silent Gliss® 4870

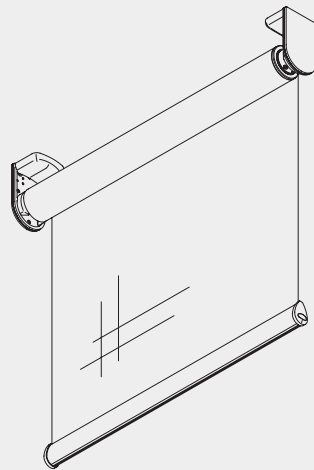

Product Information

- Medium/medium-heavy duty motorised roller blind system, ideal for contract applications
- Connected systems can be mounted using an intermediate snap-in bracket for easy fitting from below. Systems are operated simultaneously with one motor
- Adjustable stainless steel bracket set: the vertical adjustment device enables the fabric to be easily aligned with the window frame or the system with the ceiling on-site using a screwdriver only
- Pre-fitted hook-in stainless steel plates take the weight of the blind whilst the fitters carry out final positioning of the brackets. The latter are each adjustable sideways by up to 15mm
- The system can be covered with an optional fascia profile
- Electronic endstop
- Fixed switch or radio control operation
- Aluminium bottom bar, white as standard with the option of silver
- Optional side-guide wires with easy fitting and tensioning
- Bracket covers for neater appearance outside recess
- Double system option allows two blinds to be mounted in parallel on the same set of brackets - ideal when sheer and dim-out shading is required at same window
- Can be combined with Radio Remote Control System Silent Gliss 9940/0450



4870

Profile and Specification Information

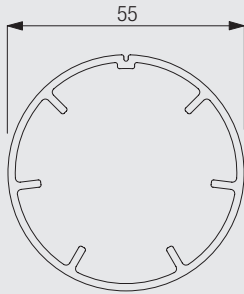

4701

Specification Guide - download from www.silentgliss.co.uk (password required).

Silent Gliss motorised roller blind system for medium/medium-heavy weight fabric applications. Fixed to wall/ceiling/inside recess with 4707 bracket set with top and side covers to ensure neat appearance. 4714 hook in plates to be used for easy on-site installation. Optional double system using brackets 4969/4971. Electronic endstop ensures stopping of blind at pre-defined height. Optional side guide wires and aluminium fascia with rubber lip available to ensure no light gap at ceiling. Side by side (linked) system 4870 can be operated simultaneously with one motor, fitted with 4708 (wall)/4709 (ceiling) centre support brackets. Supplied with in-line connector 0766 as standard.

How to Measure

Single system

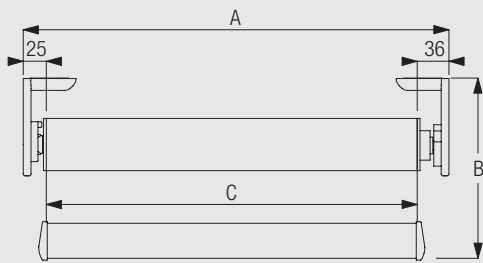

A: system width
B: system drop
C: fabric width

Attention: when installing the blind without bracket covers left and right, the total system width will be reduced by 6mm (2 x 3mm).



4870

Side by side (linked) system

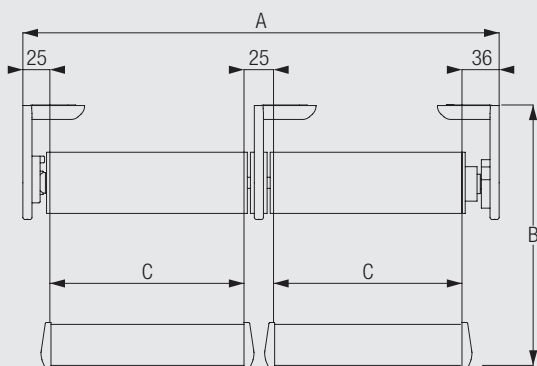

A: system width
B: system drop
C: fabric width

Attention: when installing the blind without bracket covers left and right, the total system width will be reduced by 6mm (2 x 3mm).

System with fascia 4702

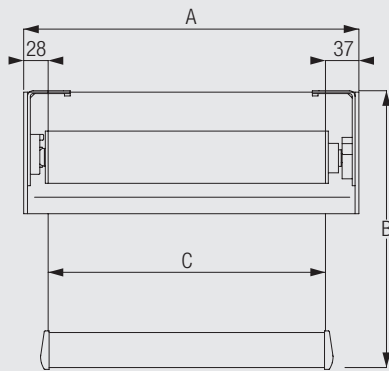

A: system width (= standard width + 8mm)

B: system drop

C: fabric width

System Dimensions



Single system: 3.30m
Side by side system
(linked): 6.60m



70cm



5m



Single system: 14
Side by side system
(linked): 22



Single system: 10kg
Side by side system:
10kg

System Options

Side by side systems (linked) with special connection bracket 4708 (face fix) and 4709 (top fix).

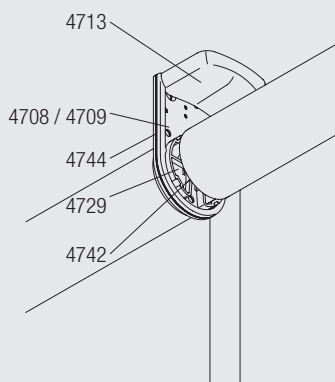

- 4708 Connection bracket for wall fixing
- 4709 Connection bracket for ceiling fixing
- 4713 Bracket cover
- 4729 Connection flange (x2)
- 4742 Connection adapter (x2)
- 4744 Connection bracket cover

The motor can only be installed at the end of each system, either left or right hand side, not in the middle.

Special connection bracket for connecting two systems so that both can be operated simultaneously with one motor only. For wall fixing use bracket 4708, for ceiling fixing 4709.



4870

Side guides for stabilising blind systems and sloped applications (up to 15° incline)

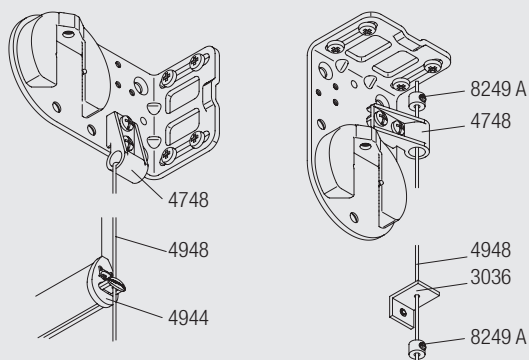

- 8249A Fastener
- 4944 Endcover
- 4948 Wire rope (1.5mm)
- 4748 Holder
- 3036 Bracket

The bracket 3134 (with cover 3133) can be used as an alternative to 3036 for greater clearance.

Fascia cover for system

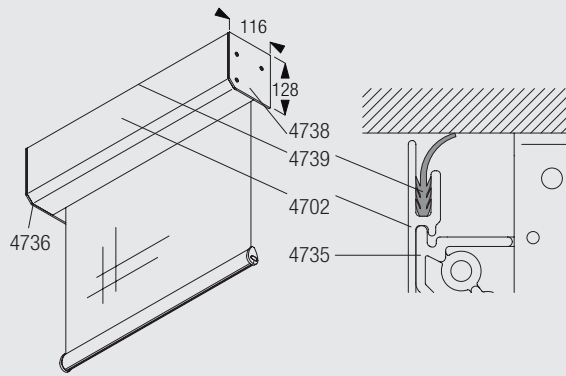

- 4702 Profile
- 4739 Seal (optional)
- 4736 Cover left
- 4738 Cover right
- 4735 Fascia holder (x2)

Fitting Information

Bracket positioning and basic fitting features

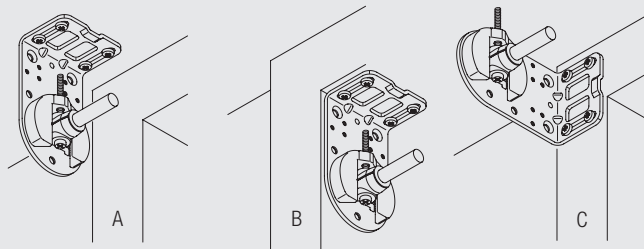

- A: Ceiling fix
- B: Recess fix
- C: Wall fix

Adjustable stainless steel bracket set (for vertical adjustments)

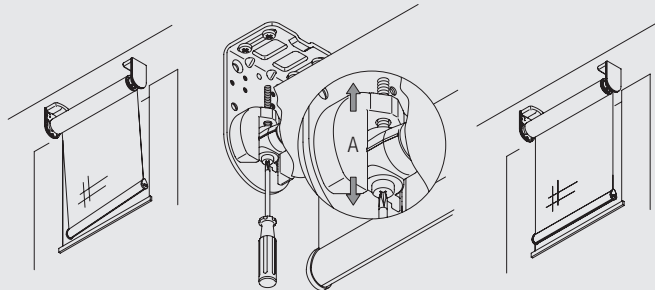
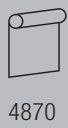

Vertical adjustment of the system (A) allows the headtube to be adjusted.

Hook-in installation plates

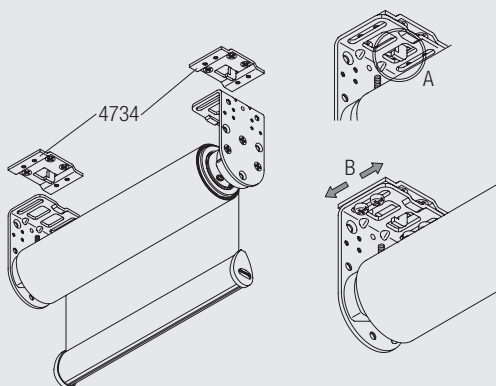

The brackets can be laterally adjusted by up to 15mm.

Specially designed pre-fitted hook-in plates (A) take the weight of the blind during the final positioning (B) of the brackets.

Ceiling fix

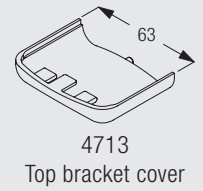
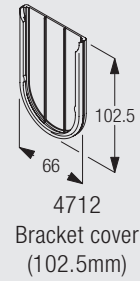
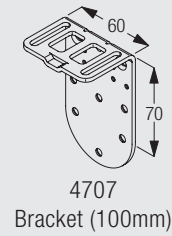
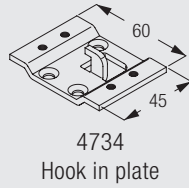
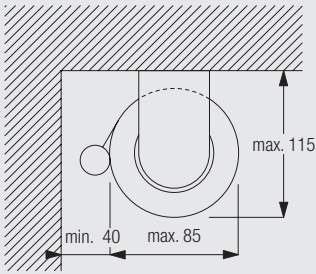

Recess fix

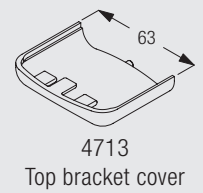
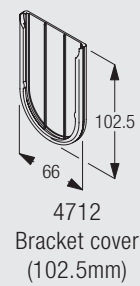
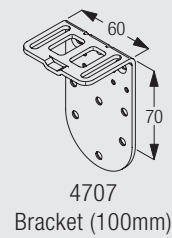
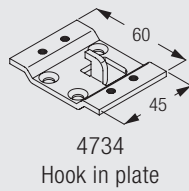
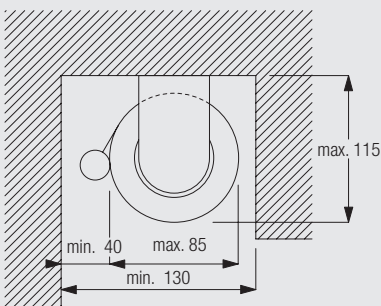

Wall fix

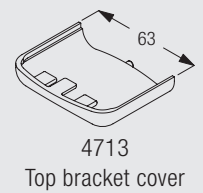
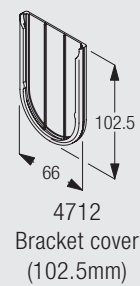
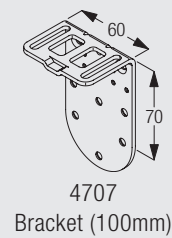
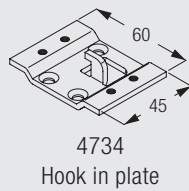
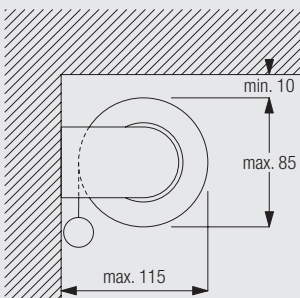

Ceiling fix with double brackets 4969 and 4971

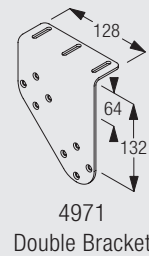
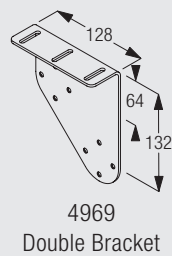
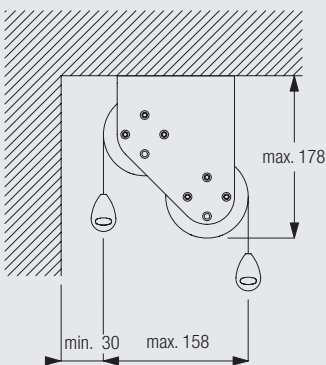

Recess fix with double brackets 4969 and 4971

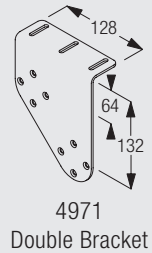
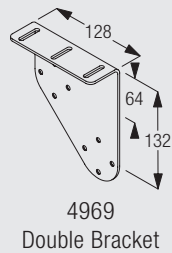
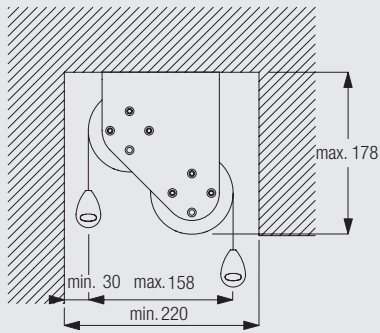



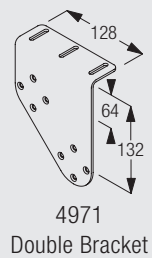
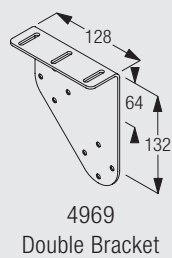
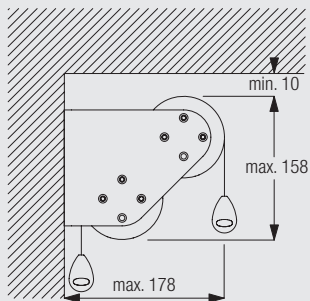



Wall fix with double brackets 4969 and 4971







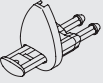
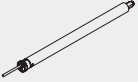





Standard Accessories

4870

			4701	Profile		
	4707	Bracket (100mm)		4712	Bracket cover (102.5mm)	
	4713	Top bracket cover		4734	Hook in plate	
	4903	Bottom bar		4944	Bottom bar endcover set	
	10522	Motor 20-Series, 230V				

Optional Accessories

	0578	Pattress box		0615	Latching switch inc. pattress box	
	0997	Motor Test Lead		3036	Bracket (47mm)	
	4702	Profile (fascia)		4708	Connection bracket double system (100mm wall fixing)	
	4709	Connection bracket double system (100mm ceiling fixing)		4735	Holder (fascia)	

4736	Cover left (fascia)		4738	Cover right (fascia)	
4739	Seal (fascia)		4744	Connection bracket cover	
4748	Holder		4948	Wire rope (ø 1,5mm)	
4969	Double Bracket		4971	Double Bracket	
5741	Klik plug		5742	Klik socket	
10523	Motor 20-Series, 230V, radio receiver				



4870

Overview Motors & Controls

Motor and Control Features	Motor

Motor Features

Electronic end-stop programming with Silent Gliss transmitters or limit setting lead	●
Electronic revolution counter (unlimited revolution)	●
Two intermediate positions possible (only applicable with built-in motor receiver)	●
Exact programming of intermediate positions possible	●
Parallel wiring possible without additional relays	●
Parallel wiring possible without additional relays with built-in motor receiver	●
Soft stop	●
No stop clicking	●
Cable connectable with plug into motor and available in different lengths	●

Control Features

Silent Gliss Radio Remote Control System 9940 (only applicable with built-in motor receiver)	●
Silent Gliss Radio Remote Control System 0450 (external receiver necessary)	●
Suitable for all common home automation and bus systems	●

Motorisation

Motors Silent Gliss 10522 / 10523 (230V)



4870

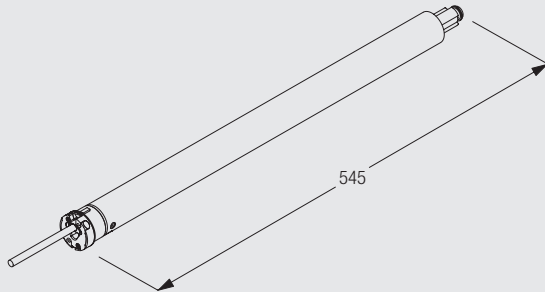

- Voltage: 230V AC
- Frequency of Receiver of Motors 10523: 915 MHz
- Torque: 3Nm
- Speed: 30rpm
- Frequency: 50Hz
- Power: 135W
- Current: 0.60A
- Thermal Overload Protection
- CE Standard
- Cable pluggable

Operating Methods

Operation via fixed switch with motor 10522

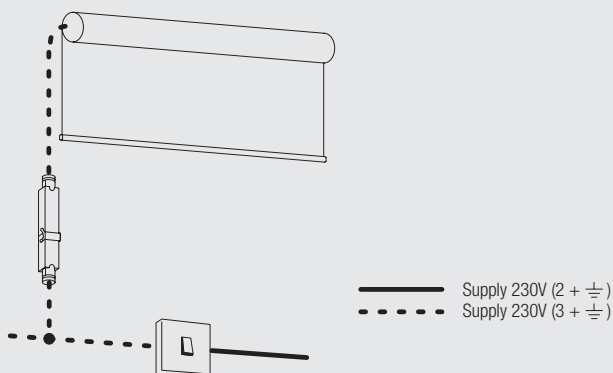

Up to 10 motors can be wired in parallel, cumulative total load must be 25% below the switch/fuse rating.

When using the Fixed Switch control for multiple blinds, when operating simultaneously the blinds may not necessarily stop at precisely the same intermediate point. Top and bottom levels can be preset in alignment.

If this is a requirement then we recommend using Radio Control System 9940/0450 with individual and simultaneous switching.

Operation with Radio Remote Control System 9940 or 0450

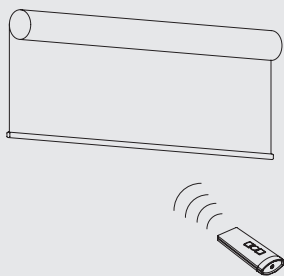

System can be combined with Radio Remote Control System Silent Gliss 9940 using motor 10523 (integrated receiver) or Radio Remote Control System 0450 using motor 10320 (non integrated receiver) with minimum wiring. For further details, please refer to catalogue section "Motors & Controls".

Wiring and Connections

Important: Wiring diagrams are available from www.silentgliss.co.uk (password required).



4870

www.silentgliss.co.uk

www.silentglissglobal.com

Silent Gliss Ltd
Pyramid Business Park
Poorhole Lane
Broadstairs
Kent
CT10 2PT
Great Britain

Tel: +44 (0) 1843 863571
Fax: +44 (0) 1843 864503
info@silentgliss.co.uk

Silent Gliss Global Ltd
Pyramid Business Park
Poorhole Lane
Broadstairs
Kent
CT10 2PT
Great Britain

Tel: +44 (0) 1843 874250
Fax: +44 (0) 1843 874457
info@silentglissglobal.com